



# Installing Your Software

The following information is intended to get you up and running with Shake 4 as quickly as possible and covers the following topics:

- Contents of the box
- Onscreen help
- Shake system requirements
- RAM Requirements
- Uninstalling Shake
- Installing Shake
- Serializing and registering Shake
- Installing and licensing Shake for render-only workstations
- Apple Qmaster system requirements
- Installing Apple Qmaster Client, Services, and Administration tools
- Shake and Apple Qmaster support

**Important:** Be sure to review the *Before You Install Shake 4* document (in the Shake 4 installer or on the installation CD). For the latest information on Shake, go to the Shake website at <http://www.apple.com/shake>.

## About the Contents of Your Shake Box

Your Shake box contains the following software and documentation.

### Installation CD

*The Shake 4 installation CD:* This is your installation disc. Use this CD to install the Shake and Apple Qmaster software and documentation.

### Printed documentation

The following printed instructional material is included in your Shake box:

- *Shake 4 User Manual:* Provides information on new features, the Shake user interface, image input and output, the compositing nodes and Node View, file formats and footage, keying, color correction and color space, using masks and transforms, working with the Curve Editor and the Time View, painting and rotoscoping tools, using filters, customizing Shake and making macros, and rendering.
- *Shake 4 Tutorials:* Provide step-by-step instructions for general Shake workflow and the user interface, basic color correction, using the Z channel, using local variables with expressions, color correction on premultiplied elements, using Keylight and Primatte, tracking, how to make a macro, and how to create a simple clean plate.

**Note:** Tutorial media for use with the *Shake 4 Tutorials* is included on on the *Shake 4* installation CD, in the *Tutorial\_Media* folder.

### PDF documentation

The following PDF documentation is located in the Documentation folder on the Shake 4 installation CD.

- *Shake 4 User Manual*
- *Shake 4 Tutorials*
- *Shake 4 New Features*
- *Installing Your Software*
- *Apple Qmaster User Manual*
- *Truelight User Manual*

## About Onscreen Help

The *Shake 4 User Manual*, *Shake 4 Tutorials*, *Shake 4 New Features*, and *Late-Breaking News* documents are accessible via the Help menu of the Shake application. The *Apple Qmaster User Manual* and *Apple Qmaster Late-Breaking News* are available in the Help menu of the Apple Qmaster application. Documentation for the bundled Truelight features is included in the *Documentation* folder, located on the Shake 4 installation CD.

## Onscreen Documentation

The Shake and Apple Qmaster onscreen documentation is in PDF format, and allows you to access information directly onscreen while you're working in Shake or Apple Qmaster via the Help menu. In Shake, there is also a Help button located in the Parameters tab of each function. This button opens an HTML page that describes the function. An additional HTML page that contains information on customizing Shake can also be accessed from the Help menu. These HTML pages (the function pages and the customizing section) include the same content as the *Shake 4 User Manual*.

### To access the onscreen help:

- Choose Shake User Manual, New Features, Tutorials, or another option from the Shake Help menu.

The onscreen PDFs are interactive and contain links for easy navigation. To quickly find a specific topic, use the bookmarks or the interactive index.

- In Apple Qmaster, choose Help > Apple Qmaster Help; in Apple Qadministrator, choose Help > Apple Qmaster Help; in Batch Monitor, choose Help > Batch Monitor Help (Batch Monitor is the utility installed with the Apple Qadministrator and Apple Qmaster Client components).

### To access the onscreen help for a specific Shake function:

- In the Node View, click the right side of the node to load its parameters.
- In the Parameters tab, click the Help button.

**Note:** In the printed user manual, all function information is included in their associated chapters.

### To access the onscreen help for customizing Shake:

- Choose Help > Customizing Shake.

**Note:** In the *Shake 4 User Manual*, extensive information on customizing is located in Chapter 14, "Customizing Shake."

## Late-Breaking News

The Late-Breaking News option in the Help menu links to the Late-Breaking News section of the Shake website and contains the latest information about the software, new features, and known bugs.

### To access Late-Breaking News:

- In the Shake application, choose Help > Late-Breaking News.
- In Apple Qmaster or Apple Qadministrator, choose Help > Late-Breaking News.

## Shake 4 System Requirements

Before you install Shake 4, make sure that your Macintosh system meets the following minimum requirements.

### Minimum Hardware and Software Configuration

- Power Mac G5; Power Mac G4 or PowerBook G4 with 1 GHz or faster PowerPC G4 processor
- Mac OS X v10.3.9 or Mac OS X v10.4 (or later)
- QuickTime 7 (or later)
- 512 MB of RAM minimum—1 GB RAM or more recommended
- 1 GB of available disk space for caching and for temporary files
- AGP graphics card with at least 32 MB of video memory and OpenGL hardware acceleration
- Display supporting 1280 x 1024-pixel resolution and 24-bit color, with 32MB or more of VRAM and Open GL hardware acceleration
- Three-button mouse

### Minimum Requirements for Render-Only Workstations

The Shake 4.0 render-only workstation requires the following minimum hardware and software configuration:

- 500 Mhz or higher PowerPC G4
- PowerPC G4 refers to any Tower, PowerBook, iMac, eMac over 500 Mhz.
- 1 Ghz PowerPC G4 or higher XServe
- Mac OS X v10.3.9 or Mac OS X v10.4 (or later)
- QuickTime 7 (or later)
- 1 GB local disk space for caching and temporary files
- 256 MB of RAM

### RAM Requirements

Real-time playback is a function of RAM, processor, image size, clip length, and graphics card. In Shake, images are loaded into memory and then played back. Current systems cannot achieve real-time playback with 2K-resolution images. With sufficient RAM and a good graphics card, files of up to 1K resolution should play back in real time.

Use the following formula to determine the amount of required memory:

$$\text{width} * \text{height} * \text{channels} * \text{bytes per channel} * \text{images} = \text{bytes}$$

For example, a single 1024 x 768 RGB 8-bit (1 byte) per channel image is:

$$1024 * 768 * 3 * 1 = 2359296 \text{ bytes}$$

Or, approximately 2.4 MB per frame.

**Tip:** To convert from bytes to megabytes (MB), divide by 1024 two times (1024 equals the number of bytes per kilobyte). Thankfully, all operating systems come with calculators. For a rough approximation, drop the last 6 digits.

An 8-bit image is 1 byte, a 10 or 16-bit image is 2 bytes, and a float image is 4 bytes.

## Installing Shake

When you install Shake, its components are placed in the *Applications* folder of the hard disk, typically your startup disk.

**Important:** Be sure to review "[Shake 4 System Requirements](#)" on page 4 before installing Shake.

## Installing Shake From the CD

Before you install Shake, turn off any virus protection and security software that you may have installed on your computer. Also, review any *Before You Install* files or documentation.

### To install and serialize Shake:

- 1 Insert the Shake 4 installation CD into your CD drive.
- 2 Double-click the Install Shake icon, then follow the onscreen instructions.
- 3 Read the Introduction, then click Continue.
- 4 Read the *Before You Install Shake 4* document, then click Continue.
- 5 Read the Software License Agreement, then click Continue and Agree.
- 6 Select the destination disk where you want to install Shake, then click Continue.
- 7 Click Install.

**Note:** If you have previously installed other Apple Pro Applications, this button may be labeled Upgrade instead of Install.

- 8 In the Authenticate window, enter your administrator name and password, then click OK.

By default, Shake is installed into a folder named "Shake" within the *Applications* folder on your hard drive.

### Shake Folder Contents

When Shake is installed, three icons appear within the *Shake* folder: *shake*, *shkv*, and *shkqtv*. The *shake* icon represents the Shake application, and can be placed in the Dock. The *shkv* icon represents the Shake Viewer application (the Flipbook player for all platforms). The *shkqtv* icon represents the Shake Disk-Based Viewer application (the QuickTime Flipbook player). You cannot launch *shkv* or *shkqtv* outside of Shake. When you create a standard or disk-based Flipbook in Shake, Shake Viewer is automatically launched and the *shkv* or *shkqtv* icon appears in the Dock.

## Serializing Shake

- 1 Double-click the Shake icon (if starting Shake from the Dock icon, single-click).
- 2 In the Licensing dialog, enter your first and last name.  
**Note:** Entering an organization is optional.
- 3 In the Serial Number field, enter the Shake 4 serial number printed on the front of this document.
- 4 Click OK.

## Registering Shake

The first time you start Shake, the application prompts you for registration information. By default, the Me card information in your Address Book is automatically entered in the appropriate fields.

**To register Shake to a user other than the user listed in the Me card in your Address Book:**

- 1 Fill out the Name, Address, Organization, and Email address fields.
- 2 If you want information about Apple news and software updates sent to your email account, select the checkbox.
- 3 If you want to review Apple's Privacy Policy, click Privacy Policy.
- 4 When you are finished, click Register Now.

You are now ready to begin using Shake.

**Note:** If you decide to click the Register Later button, you will be prompted to register again after opening the application five times.

## Installing and Licensing Shake for Render-Only Workstations

To install the render-only version of Shake, perform the CD install as described in "[Installing Shake](#)" on page 5 on all systems intended for use as render workstations. Mac OS X render licenses are free, and do not require serial numbers or special licensing.

## Uninstalling Shake

This section discusses uninstalling Shake and its associated files.

**Important:** Although custom files are generally stored in the *nreal* folder of the *Users* directory, be sure to back up any custom files that may be stored in the *Shake* directory that you want to save before you uninstall Shake.

### To uninstall Shake:

- 1 Drag the *Shake* folder to the Trash (located in the Dock).
- 2 In the *Library/Receipts* folder, drag the *Shake.pkg* file to the trash.
- 3 Empty the Trash contents.

**Note:** If the *Shake4.0.pkg* file is not removed from the *Receipts* folder prior to installing Shake again, the Shake Installer shows that you are upgrading Shake. The *Shake4.0.pkg* file is simply overwritten.

This process does not remove the *nreal* folder in the user directory that is created when Shake is run for the first time. This folder usually contains your custom settings, such as macros, machine and user interface settings, icons, and autosaved scripts.

## Installing Apple Qmaster 2

Apple Qmaster 2 is available via a separate installer on the installation CD. For more information on the Apple Qmaster 2 components and installation, see the *Apple Qmaster 2 User Manual*, located in the *Documentation* folder of the Shake 4 installation CD.

By default, the Apple Qmaster 2 installer places Apple Qmaster and Apple Qadministrator icons in the *Applications* folder, and the Batch Monitor in the *Applications/Utilities* folder. It also installs the Apple Qmaster Preferences Panel, which lets you set your computer up as a service node.

### Minimum Requirements for Apple Qmaster 2

- *Software requirements:* Mac OS X v10.3.9 (or later)
- *Hard disk drive requirements:* The Apple Qmaster applications and Apple Qmaster services require at least 20 MB available disk space for application installation.

## Apple Qmaster Installation Components

Within the Customize dialog in the Apple Qmaster installer are two separate installation components for Apple Qmaster, each designed for a different part of a Apple Qmaster system.

Installation Component	Where to Install It	Applications and Utilities Installed
Apple Qmaster Applications	<p>On <i>client computers</i>: Any computer from which you use Shake Qmaster to submit processing jobs.</p> <p>On <i>administrator computers</i>: Any computer you use to create and administer Shake Qmaster clusters. It must be on the same network as the clusters.</p>	<ul style="list-style-type: none"><li>• Apple Qmaster 2 (the interface for submitting jobs for distributed processing)</li><li>• Apple Qadministrator</li><li>• Batch Monitor utility</li></ul>
Apple Qmaster Services	<p>On <i>cluster computers</i>:</p> <ul style="list-style-type: none"><li>• <i>service nodes</i>: The computers that perform the actual processing of jobs.</li><li>• <i>cluster controller computers</i>: The computer that acts as the manager of a cluster. It divides up tasks, determines which service nodes to send work to, and then distributes the work.</li></ul> <p>There is only one cluster controller per cluster.</p>	<ul style="list-style-type: none"><li>• Apple Qmaster 2 pane in System Preferences</li></ul>

While one computer could act as a combination of client, service node, and cluster controller, keeping these functions on separate computers generally increases the speed and efficiency of processing.

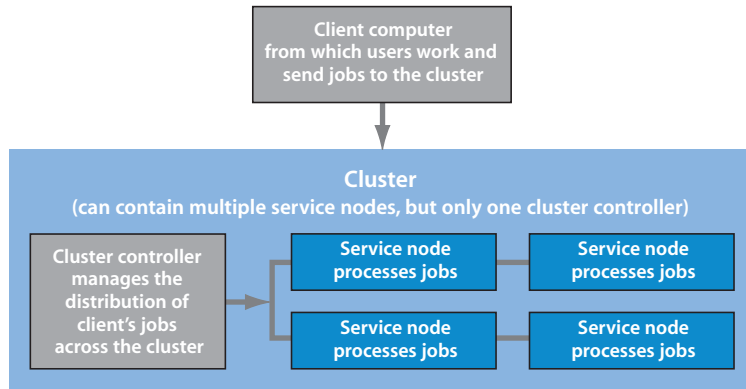

#### Example of a network setup for distributed rendering

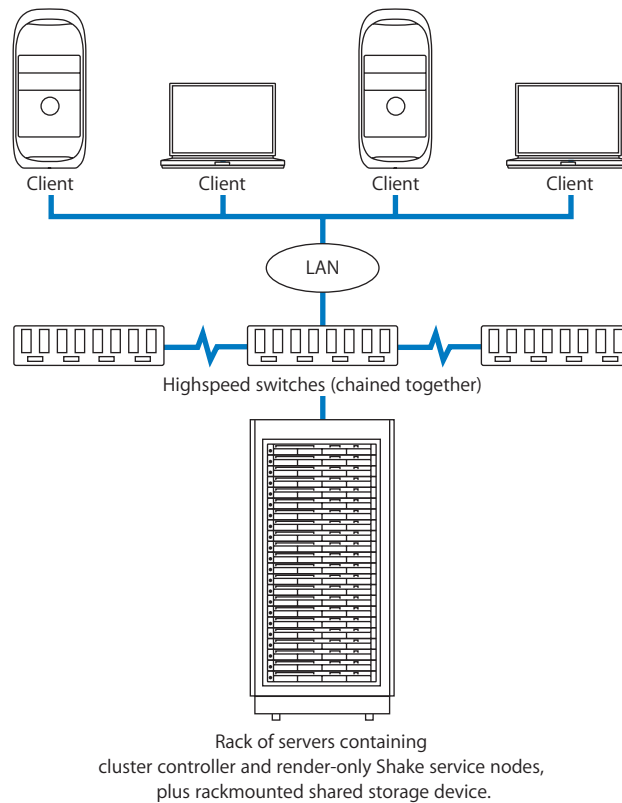

For more background information about the different parts of an Apple Qmaster system and how to prepare an Apple Qmaster network, see the Apple Qmaster 2 documentation. To open the *Apple Qmaster User Manual* included on the installation CD, double-click the Apple Qmaster 2 User Manual.pdf icon in the documentation folder.

### Using Apple Remote Desktop to Create and Administer Shake Cluster Computers Remotely

You can conveniently set up and control Shake service nodes and cluster controllers over a network or over the Internet, using Apple Remote Desktop. Apple Remote Desktop, using real-time screen sharing, lets you configure and administer Shake service nodes and cluster controllers that are running Mac OS X. For example, from one computer, you can turn services on and off and mount shared storage devices on cluster computers. You can also use Apple Remote Desktop to distribute or install the software, configure headless service nodes, and control desktops from anywhere on the network. For more information, see

<http://www.apple.com/remotedesktop/>

For details on configuring and managing service nodes, cluster controllers, and clusters, see the Apple Qmaster 2 documentation.

You can install both of the Apple Qmaster software components on any computer in your Apple Qmaster system, but you do not need to. The instructions that follow tell you how to install only the necessary components on each computer.

**Important:** All the computers in a cluster need Read and Write access to any computers (or storage devices) that will be specified as output destinations for files.

### Installing Apple Qmaster Applications on Client and Administrator Computers

You need to install Apple Qmaster Applications on any computer that you use to submit processing jobs with Apple Qmaster, and on any computer from which you create and administer Apple Qmaster clusters. Apple Qmaster is available from a separate installer.

**Note:** When using Apple Qmaster 2, Shake is not required to be installed on client and administrator computers.

#### To install Apple Qmaster Applications on client or administrator computers:

- 1 Double-click the Install Apple Qmaster 2 icon.
- 2 Follow the onscreen instructions.

## Installing Apple Qmaster Services on Cluster Computers

You need to install Apple Qmaster on cluster computers (service nodes and cluster controller computers). Keep in mind that while it is possible for each cluster to have multiple service nodes, you are only required to have one cluster controller per cluster.

On service nodes, you also need to install the application that will process batches submitted to Apple Qmaster. For Shake clusters, you can install Shake and the render license on the service nodes, since the only component of Shake that you need in a service node is its rendering capability. Shake 4 and Apple Qmaster 2 are available as separate installers. For more information on installing Shake 4.0 for rendering, see [“Installing and Licensing Shake for Render-Only Workstations”](#) on page 6. See the previous section for more information on installing Apple Qmaster 2.

When Apple Qmaster Services are installed, the Apple Qmaster icon appears in the “Other” group of System Preferences.

**Note:** See [“Special Installation Instructions for Extended Node Clusters”](#) on page 11 for information about creating an extended node cluster. You do not need to install any Apple Qmaster software on extended service nodes, but an extended node cluster does require an intermediary node that needs Apple Qmaster Services.

## Special Installation Instructions for Extended Node Clusters

There is a way to use computers as service nodes even if they do not have Apple Qmaster installed. To do this, you configure an intermediary node that executes Apple Qmaster commands on other computers, called extended nodes. The intermediary node runs UNIX commands on the extended nodes via the SSH (secure shell) UNIX program, so that the extended nodes can process batches without having Apple Qmaster installed. This type of cluster is called an extended node cluster.

**Note:** See the Apple Qmaster documentation for details on configuring and using an extended node cluster. To open the Apple Qmaster Help included on the installation CD, double-click the Apple Qmaster Help.pdf icon.

You only need one intermediary node in an extended cluster. It can act as the cluster controller, or you can add it to another cluster that already has a cluster controller.

### To install Apple Qmaster on the intermediary node:

- Double-click the Install Apple Qmaster 2 icon, and follow the onscreen instructions.

### To install Apple Qmaster 2 on the extended nodes:

- Double-click the Install Shake 4 icon to install Shake on any computer that is intended for use as an extended node. There is no need to install Apple Qmaster software on extended nodes. Computers acting as extended nodes can operate as render-only workstations. See [“Installing and Licensing Shake for Render-Only Workstations”](#) on page 6 for more information.

## About Installing Software and Saving Files

Mac OS X provides a multiuser environment so everyone has their own home directory where they can save files that aren't accessible to others. If users are working on the same projects, they need to save or place these files in a location where others can access the files.

When installing or saving files, including project files, consider who needs access to these items. Use the following to help determine where to locate files:

- *Shared folder within the Users directory:* All users have access to this folder, making this a good location to save and store files that you want others to use.

*Computer/Volume/Users/Shared*

For example, if you want all users to have access to the tutorial media, copy the appropriate folder from the Shake 4 installation CD to this *Shared* folder in the *Users* directory on a volume root.

- *Public folder within a user's home directory:* The user must turn on file sharing in Sharing preferences so other users can access this folder.

*Computer/Volume/Users/Username/Public* OR *Home/Public*

- *Volume roots:* All users typically have access to the volume roots, which are all of the connected volumes or hard disk drives. If all users need access to specific applications, such as Shake, make sure you install these applications in an accessible folder on a volume root, such as the Applications folder.

**Note:** For information on setting preferences and environment variables, see Chapter 14, "Customizing Shake," in the *Shake 4 User Manual*.

## Shake and Apple Qmaster Support

For support information, see the "Shake Services and Support Guide" card that is included in your Shake box.